

ELBA E/Z, FROSTED DIFFUSER PMMA



TECHNICAL DATA

Diffuser	frosted (PMMA)
Power	23 W
Application	parks, pedestrians, bicycle routes
Assembly	pole top mounted or on extension arms with $\varnothing 60 \times 50$ mm ending
Colour	painted in black colour
Ingress protection	IP 65
Material	base – high-pressure die-casted aluminium alloy cap – formed aluminium sheet diffuser – frosted cylindrical $\varnothing 200$ mm (PMMA)
Input voltage frequency	50 Hz
Supply voltage	230V AC
Electrical gear cover	mounted on gear frame, magnetic ballast with thermal protection, metal halide lamps MH 70W (EL) optionally available with electronic ballast
Mounting method	only upwards
Light source type	LED E-27



Code	Symbol	Diffuser	LED power	Luminaire power consumption	Unit volume	Effective projected area	Light source type	Exemplary lamp types	Net weight
2134015	ELBA E/Z, frosted diffuser PMMA	frosted (PMMA)	-	23 W	0.06 m ³	0.115 m ²	LED E-27	Philips: 23W Osram: 23W	6.5 kg

: 2014/35/UE (Official Journal of the UE L 96/357 29.03.2014), 2014/30/UE (Official Journal of the UE L 96/79 29.03.2014), 2011/65/UE, 2009/125/EC
: PN-EN 60598-1: 2015, PN-EN 60529: 2003, PN-EN 62262: 2003, PN-EN 55015: 2013, PN-EN 61547: 2009, PN-EN 61000-3-2: 2014, PN-EN 61000-3-3: 2013,

TECHNICAL DRAWING

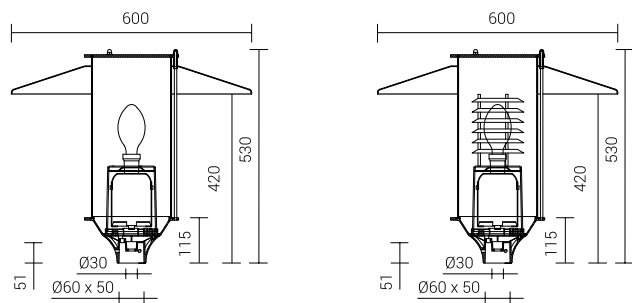

ELBA S-70

