

TECHNICAL DATA

Assembly	installed on the aluminium rail on the back wall of the column using two M6 bolts
Ingress protection	IP 54
Material	integrated terminal strip – made of PTB material (butylene polyterephthalate), with high insulation parameters and high mechanical resistance; connection cover and clamp/cable protection – made of transparent polycarbonate; connection box base – made of polycarbonate reinforced by fibre glass, cable opening/outlets are protected with gaskets brass clamps and steel screws to connect the lower part with the cover
Number of fuse-sockets	Two fuse-socket mounted on L1 and L2 phase, there is a possibility of moving the fuse-socket into phase L3 by screwing-out two bolts
Description	5 tracks connection boxes for feeder cables with cross-section from 5 x 10 mm ² to 5 x 25 mm ² for Cu from 5 x 16 mm ² to 5 x 35 mm ² for Al max. 2 cables the possibility of splitting load into particular phases the possibility of moving the fuse-sockets



Code	Symbol	Unit volume	Fuse sockets quantity	Protection class	Rated insulation voltage	Withstand stroke voltage rating	Rated current	Net weight
324112	NTB-12	0.002 m ³	1	II	500V	6 kV	80A	0.9 kg

DIRECTIVES: 2014/35/UE (Dz. Urz.UE L 96, 29.03.2014, str.357), 2011/65/UE (Dz. Urz.UE L 174, 01.07.2011, str.88)

STANDARDS: PN-EN 60529: 2003, PN-EN 50102: 2001, PN-EN 61439-1: 2011, PN-EN 61439-2: 2011

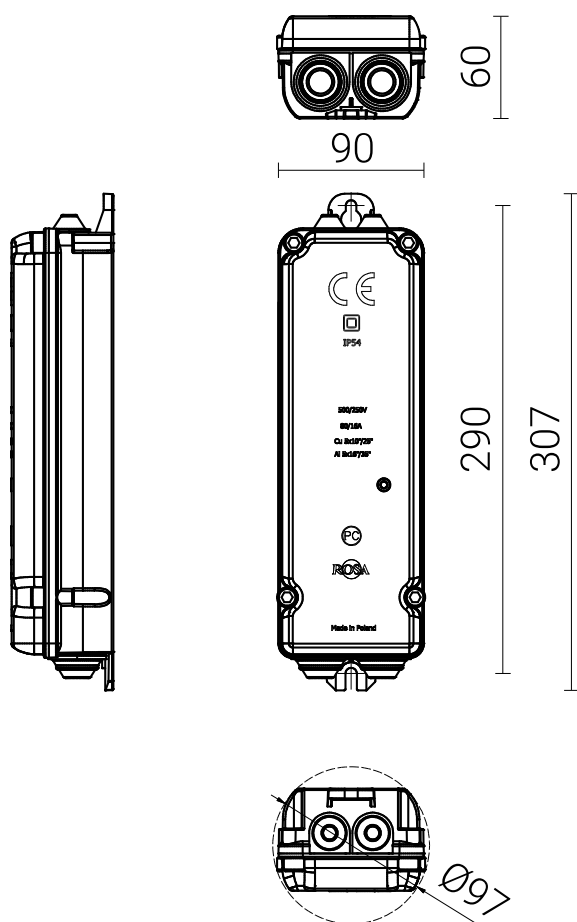

Fuse-link D01

Fuse-link typej	Code	Weight
D01/E14 6A	322006	0,01kg
D01/E14 10A	322010	0.01kg
D01/E14 16A	322016	0.01kg